

DESCRIPTION



front view



angled view

The TConn 4.3 is a cost-efficient HMI system with a 4.3 inch screen. It features an optically bonded is-play with a brightness of up to 800 candela/m² (nits). The display offers a resolution of 480 x 272 pixels. The HMI system is powered by an i.MX6 processor with 528 MHz, 2 GB memory and 256 MB RAM. Application programming via Topcon ProjectorTool, C/C++ or CODESYS.

TECHNICAL SPECIFICATION

Housing	Glass, PC/ABS, Autotex XEF200
Connector	1. Main: Deutsch DT06-08SA 2. Back USB: USB-Type C
Weight	~260 g
Temperature range (ISO 16750-4 compliant)	-30 °C to +75 °C
Environmental protection acc. to ISO 20653	IP66 and IP67 CAUTION! Follow the mechanical instructions!
Current consumption	ON: < 165 mA at 12 V OFF: ~ 2 mA at 12 V
Operating voltage	9 to 36 V (Code C at 12 V, Code E at 24 V, acc. to ISO 16750-2)
Oversvoltage protection	5 min at +48 V
Reverse polarity protection	Yes (5 min at -48 V)
CAN Interfaces	2 x ISO 11898, CAN-specification 2.0 B active, CAN FD tolerant
USB Interfaces	USB 2.0, Type C, high speed, 1A, short protected against Vbus, thermal protected, fault flag

TECHNICAL DATA

Display Features	Description
Size	4.3"
Resolution	480 x 272 px; 15:9
Colors	16.7 Mio
Brightness	typ. 800 cd/m ²
Contrast ratio	typ. 800:1

In-/Output Devices	Description
Touch	PCT, Multi (5) Gloves support
Indicators and sensors	4 keys with fluorescent print w/o Backlight

Processor	Description
CPU	Freescale NXP i.MX 6 ULL 32-bit MPU, ARM Cortex-A7 core, 528 MHz
Mass storage	2 GB (4GB eMMC in pSLC-Mode)
RAM	256 MB, DDR3L, 1600 Mbps
RTC	run time counter, without buffer
Buzzer	92 dB(A) 10cm at 2700 Hz

SOFTWARE/PROGRAMMING

Linux

Topcon Projektor Tool, C/C++, CODESYS (if requested)

CE-COMPLIANCE

EU Directive 2014/30/EU (EMC) according to

- EN 13309: Construction machinery – Electromagnetic compatibility of machines with internal electrical power supply
- EN ISO 14982: Agricultural and forestry machinery - Electromagnetic compatibility - Test methods and acceptance criteria
- EN 50498: Electromagnetic compatibility (EMC). Product family standard for aftermarket electronic equipment in vehicles
- EN 12895: Industrial Trucks – Electromagnetic compatibility
- EN 61000-6-2: Electromagnetic compatibility (EMC) - Generic standards - Immunity for industrial environments
- EN 61000-6-4: Electromagnetic compatibility (EMC). Generic standards. Emission standard for industrial environments

REGULATORY APPROVALS AND TESTING

E1 approval	ECE R10 06 10279
Electrical tests	EMC emission radiated; EMS immunity radiated; EMC emission conducted (Pulse 1, 2a, 2b, 3a, 3b, 4 (Starting profile), Load dump) ESD (± 4 and ± 8 kV contact discharge, ± 4, ± 8, and ± 15 kV air discharge) Reverse polarity Overvoltage resistance Start behavior Superimposed alternating voltage De-/increase supply voltage Drop in supply voltage Battery less operation
Mechanical tests	Vibration, noise and sinusoidal Endurance test Mechanical shock Drop test Package drop test
Climate tests	Salt spray resistance Damp heat, steady and cyclic Operating temperature range Storage temperature Temperature cycling test Temperature shock test UV-resistance
Chemical tests	Alcohol, Antifreeze liquid (Ethyl-glycol), Diesel oil, Domestic Ammonia, Gasoline, Hydraulic oil 10W40, Liquid lime, Motor oil, NPK Chemical fertilizers 20 10 20, Windscreen cleaning mixture, Ammonium Nitrate and Ammonium Phosphate fertilizers, Bovine Effluent (up to 5% propionic acid), Diesel fuel, STOU (Super Tractor Universal Oil) Lubricating oil

PIN ASSIGNMENT - MAIN (CONNECTOR 1)

Pin	Description
1	Service Enable
2	KL15, ignition contact
3	Ground / contact 31
4	KL30, supply voltage
5	CAN bus 2 low
6	CAN bus 2 high
7	CAN bus 1 low
8	CAN bus 1 high

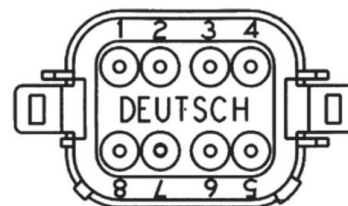

TECHNICAL DRAWING (IN MM)

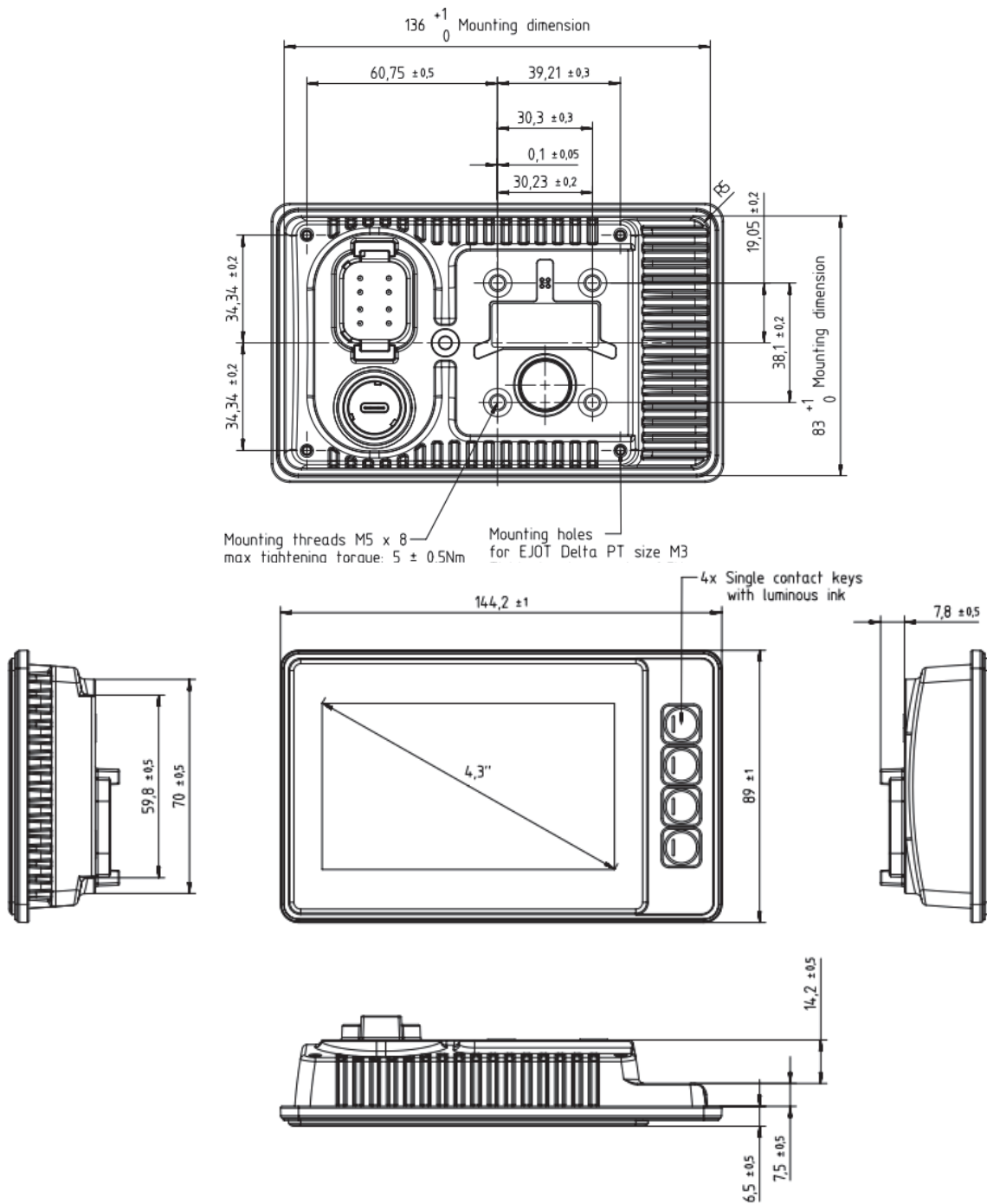

ACCESSORIES

Description	Order number
Cable Set TConn	504508
Connector Kit TConn DT06-8P	302520



MANUFACTURER

Topcon Electronics GmbH & Co KG
Industriestraße 7
65366 Geisenheim
Germany

NOTES ON WIRING AND CABLE ROUTING

The control unit must be protected against overload.

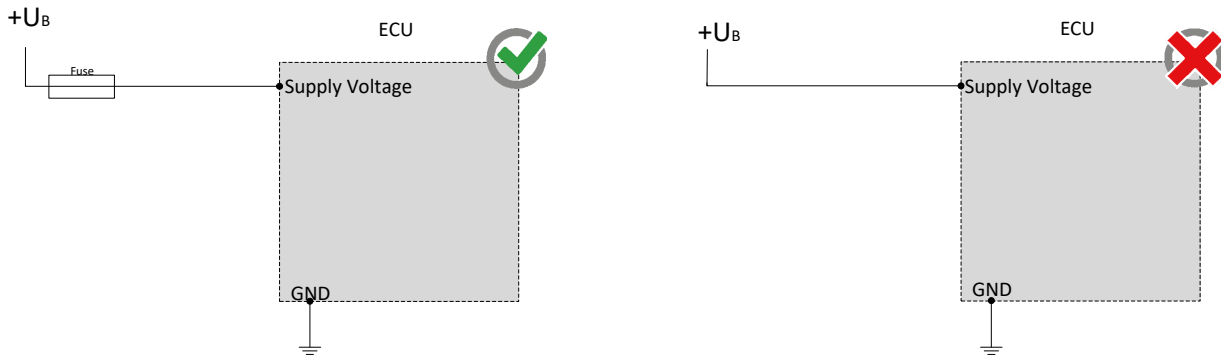

CAN bus communication is the main communication between the control unit and the vehicle. Therefore, connect the CAN bus with special care and check the correct communication with the vehicle to avoid undesired behavior.

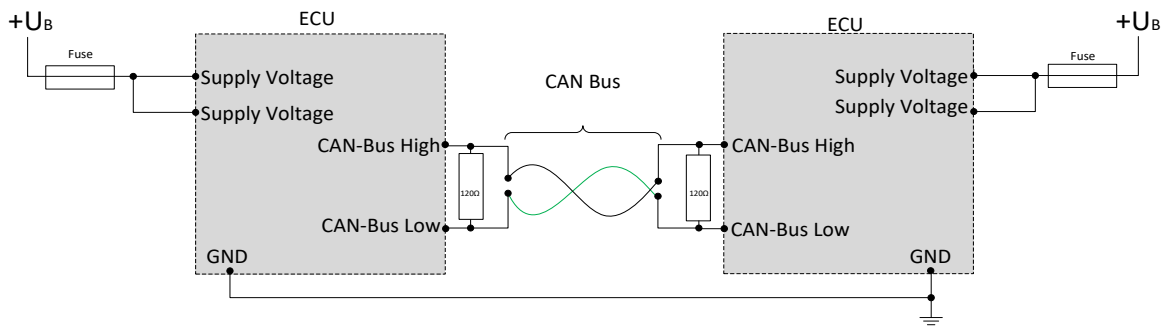

In order to achieve the environmental protection class, the cover including the seal must be correctly installed. To do this, ensure that the seal is correctly seated. Also, unused pin connections must be sealed with blind plugs.

SAFETY AND INSTALLATION INFORMATION

It is essential to read the instructions in full thoroughly before working with the device.

Please note and comply with the instructions in the operating instructions and the information in the device data sheet, see www.mrs-electronic.com

Staff qualification: Only staff with the appropriate qualifications may work on this device or in its proximity.

SAFETY



WARNING! Danger as a result of a malfunction of the entire system.

Unforeseen reactions or malfunctions of the entire system may jeopardise the safety of people or the machine.

- Ensure that the device is equipped with the correct software and that the wiring and settings on the hardware are appropriate.



WARNING! Danger as a result of unprotected moving components.

Unforeseen dangers may occur from the entire system when putting the device into operation and maintaining it.

- Switch the entire system off before carrying out any work and prevent it from unintentionally switching back on.
- Before putting the device into operation, ensure that the entire system and parts of the system are safe.
- The device should never be connected or separated under load or voltage.



CAUTION! Risk of burns from the housing.

The temperature of the device housing may be elevated.

- Do not touch the housing and let all system components cool before working on the system.

PROPER USE

The device is used to control or switch one or more electrical systems or sub-systems in motor vehicles and machines and may only be used for this purpose. The device may only be used in an industrial setting.



WARNING! Danger caused by incorrect use.

The device is only intended for use in motor vehicles and machines.

- Use in safety-related system parts for personal protection is not permitted.
- Do not use the device in areas where there is a risk of explosion.

Correct use:

- operating the device within the operating areas specified and approved in the associated data sheet.
- strict compliance with these instructions and no other actions which may jeopardise the safety of individuals or the functionality of the device.

Obligations of the manufacturer of entire systems

It is necessary to ensure that only functional devices are used. If devices fail or malfunction, they must be replaced immediately.

System developments, installation and the putting into operation of electrical systems may only be carried out by trained and experienced staff who are sufficiently familiar with the handling of the components used and the entire system.

It is necessary to ensure that the wiring and programming of the device does not lead to safety-related malfunctions of the entire system in the event of a failure or a malfunction. System behaviour of this type can lead to a danger to life or high levels of material damage.

The manufacturer of the entire system is responsible for the correct connection of the entire periphery (e.g. cable cross sections, correct selection/connection of sensors/actuators).

Opening the device, making changes to the device and carrying out repairs are all prohibited. Changes or repairs made to the cabling can lead to dangerous malfunctions. Repairs may only be carried out by MRS.

Installation

The installation location must be selected so the device is exposed to as low a mechanical and thermal load as possible. The device may not be exposed to any chemical loads.

Install the device in such a manner that the plugs point downwards. This means condensation can flow off the device. Single seals on the cables/leads must be used to ensure that no water gets into the device.

Putting into operation

The device may only be put into operation by qualified staff. This may only occur when the status of the entire system corresponds to the applicable guidelines and regulations.

FAULT CORRECTION AND MAINTENANCE



NOTE The device is maintenance-free and may not be opened.

- If the device has damage to the housing, latches, seals or flat plugs, it must be taken out of operation.

Fault correction and cleaning work may only be carried out with the power turned off. Remove the device to correct faults and to clean it.

Check the integrity of the housing and all flat plugs, connections and pins for mechanical damage, damage caused by overheating, insulation damage and corrosion. In the event of faulty switching, check the software, switches and settings.

Do not clean the device with high pressure cleaners or steam jets. Do not use aggressive solvents or abrasive substances.